



SPOT FREE RINSE SYSTEM SPECIFICATIONS

MODELS 1800 - 3000					
ELECTRICAL SERVICE REQUIREMENTS					
Pump		Full Load Amps (not including RP)			
3/4 HP		208-230 VAC, SINGLE PHASE, 6 AMP			
FEED WATER SUPPLY			PRODUCT & REJECT		
Flow	Size	Flow	Size	Flow	Size
2-5 GPM	3/4"	< 3 GPM	1/2"		
UNIT DIMENSIONS					
A	B	C	D	E	Weight
Height Overall	Width	Depth	Height to Feed Water Supply	Height to Product & Reject	
75"	23"	24"	20"	42"	< 200 lbs
MODELS 4400 - 6600					
ELECTRICAL SERVICE REQUIREMENTS					
Pump		Full Load Amps (not including RP)			
5 HP		208-230 VAC, 3 PHASE, 16/8 AMP			
FEED WATER SUPPLY			PRODUCT & REJECT		
Flow	Size	Flow	Size	Flow	Size
6-12 GPM	1"	< 7 GPM	3/4"		
UNIT DIMENSIONS					
A	B	C	D	E	Weight
Height Overall	Width	Depth	Height to Feed Water Supply	Height to Product & Reject	
75"	32"	30"	20"	42"	< 300 lbs
MODELS 8800 - 10,800 - 12,800					
ELECTRICAL SERVICE REQUIREMENTS					
Pump		Full Load Amps (not including RP)			
5 HP		208-230/460 VAC, 3 PHASE, 16/8 AMP			
FEED WATER SUPPLY			PRODUCT & REJECT		
Flow	Size	Flow	Size	Flow	Size
11-12 GPM	1-1/4"	< 10 GPM	3/4"		
UNIT DIMENSIONS					
A	B	C	D	E	Weight
Height Overall	Width	Depth	Height to Feed Water Supply	Height to Product & Reject	
75"	32"	30"	20"	42"	< 400 lbs

PROPAK ... the next generation spot free rinse.

Huron Valley Sales Inc • 151 S. Industrial Drive • Saline, MI 48176
Phone 734-944-5200 • Fax 734-944-5800 • sales@huronvalleysales.com



SPOT FREE RINSE SYSTEM SPECIFICATIONS

**MODELS 17,600 – 21,600 – 26,600
TWIN ALTERNATING**

ELECTRICAL SERVICE REQUIREMENTS

Pump	Full Load Amps (not including RP)
(2) 5 HP	208-230/460 VAC, 3 PHASE, 32/16 AMP

FEED WATER SUPPLY

Flow	Size	Flow	Size
22-40 GPM	1-1/4"	< 20 GPM	1"

PRODUCT & REJECT

UNIT DIMENSIONS

A	B	C	D	E	Weight
Height Overall	Width	Depth	Height to Feed Water Supply	Height to Product & Reject	
75"	49"	30"	20"	42"	< 600 lbs

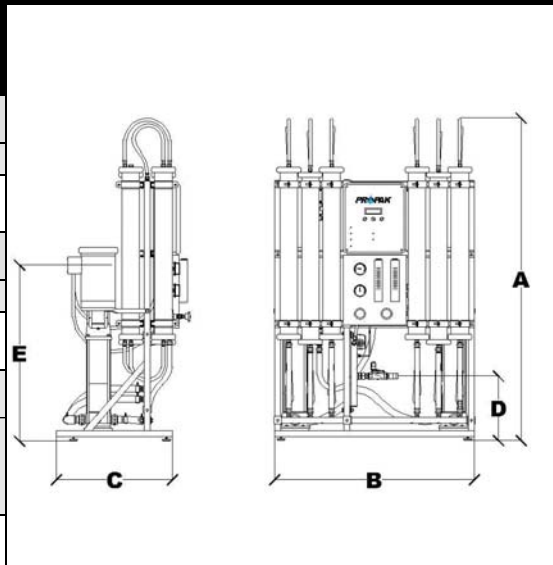

INSTALLATION REQUIREMENTS

PARAMETER	LIMITS
HARDNESS	< 1 grain for up to 50% recovery
IRON (FE)	< 0.1 mg/l
FREE CHLORINE	< 0.1 mg/l
TURBIDITY	SDI < 5
MANGANESE	none allowable
HYDROGEN SULFIDE	< 1 mg/l
TOTAL DISSOLVED SOLIDS	up to 2,000 mg/l
TEMPERATURE	40°F to 80°F (4.5°C to 26.7°C)

TYPICAL INSTALLATION SCHEMATIC

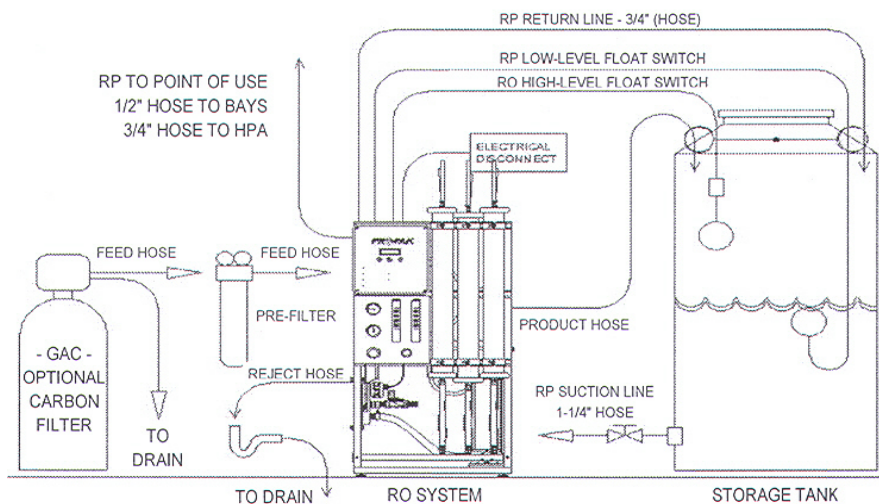

PROPAK ... the next generation spot free rinse.

Huron Valley Sales Inc • 151 S. Industrial Drive • Saline, MI 48176
Phone 734-944-5200 • Fax 734-944-5800 • sales@huronvalleysales.com